



Electrolux



Electrolux

Warewashing Undercounter Dishwasher with detergent dispenser & drain pump

Warewashing Undercounter Dishwasher with detergent dispenser & drain pump

ITEM # _____

MODEL # _____

NAME # _____

SIS # _____

AIA # _____



Warewashing

Undercounter Dishwasher with detergent dispenser & drain pump

400074 (EUCAIDDG)

Undercounter dishwasher, single skin with powered atmospheric boiler (4,5 kW), drain pump and detergent dispenser, 720d/h - wrc

Short Form Specification

Item No. _____

304 AISI stainless steel front and side panels, door, control panel and wash tank. Double skinned door. Wash tank with rounded corners. Wash arms and jets in polypropylene, easy to remove. 2 wash cycles 90/180 seconds. Soft start wash pump to avoid accidental breakage of dishes/glasses. Washing system with rotating washing arms, large capacity wash pump and tank volume. Built-in atmospheric boiler (4,5 kW), 5.8 liter capacity (allows cold water supply from 10-60°C), with rinse pump to guarantee a constant hot rinse temperature of 84°C. Boiler with 304 welding for protection against corrosion. Drain pump. Electronic controls with temperature display. External connecting box protected by a waterproof plastic cover. High efficiency air gap (class A) in water inlet circuit to avoid water being syphoned back into the network as a result of a sudden drop in mains pressure. Pre-arrangements for HACCP system implementation and energy Management device. Self-cleaning cycle. Rinse aid dispenser. Detergent dispenser. Hourly capacity: 720 dishes/40 baskets mm500x500. Supplied with: n. 1 basket for plates and n. 1 cutlery holder.

Main Features

- Built-in atmospheric boiler sized to raise incoming 50 °C water to 84 °C minimum for sanitizing rinse. No external booster is required.
- Built-in rinse aid dispenser with automatic initial and continuous cycle loading for perfect result while minimizing service and maintenance needs.
- Constant temperature of 84 °C throughout the rinsing cycle regardless of the network's water pressure and temperature.
- Unique temperature interlock guarantees required temperatures in both the wash and final rinse.
- Washing capacity of 40 baskets or 720 dishes per hour.
- Incorporated Soft Start feature to offer additional protection to more delicate items.
- High efficiency air gap (class A) in water inlet circuit to avoid water being siphoned back into the network as a result of a sudden drop in main pressures.
- 4 second (variable) pause after washing and before rinsing ensures that no drops of unclean water will fall on the clean items at the end of the rinsing cycle.
- Fault auto-diagnosis system.
- An effective rinse system uses only 3 litres of clean hot water per basket for lower running costs.
- Utilizes fresh hot rinse water.
- Low noise level.
- IPX 4 water protection.
- State-of-the-art electronic controls with built-in programming, self-diagnostics for serviceability and automatic interior self-cleaning cycle.
- Digital read-out keeps operator informed as to temperatures.
- 90/180 seconds cycle.

Construction

- Heavy duty Stainless steel construction.
- Internal cavity as well as exterior panels are all 304 series Stainless steel.
- Interchangeable wash/rinse arms screw out for simple clean up.
- Large deep drawn wash tank and internal wash area with round corners and no pipes to avoid dirt built-up.
- Element protection from dry fire and low water.
- The boiler drain facilitates the evacuation of stagnant water after long periods of inactivity to ensure a higher level of hygiene.
- Unit to include drain, detergent and rinse aid dispenser pumps
- Single phase electrical connection.

APPROVAL: _____

Included Accessories

- 1 of Stainless steel tank filter for single skin undercounter PNC 864222
- 1 of Yellow cutlery container PNC 864242
- 1 of Basket for 48 small cups or 24 cups - blue PNC 867007

Optional Accessories

- 12lt external manual water softener PNC 860412
- 8lt external automatic water softener PNC 860413
- Stand for undercounter dishwasher PNC 860418
- 20lt external manual water softener PNC 860430
- Integrated HACCP kit PNC 864001
- HACCP printer kit PNC 864002
- External detergent level probe kit PNC 864004
- External rinse aid level probe kit PNC 864005
- Drain pump kit for 50Hz dishwashers PNC 864012
- Stainless steel inlet hose kit PNC 864016
- Filter for partial demineralization PNC 864017
- Kit to measure total and partial water hardness PNC 864050
- Detergent dosing kit PNC 864218
- Yellow cutlery container PNC 864242
- AISI 304 stainless steel back panel for undercounters EUC PNC 864246
- Filter for total demineralization PNC 864367
- Pressure reducer for single tank dishwasher PNC 864461
- Half size basket universal PNC 864527
- Half size basket for plates PNC 864528
- Half size basket for glasses PNC 864529
- Kit 4 plastic boxes for cutlery - yellow PNC 865574
- Basket for 18 dinner plates - yellow PNC 867002
- Basket for 48 small cups or 24 cups - blue PNC 867007
- Cover rack for small and light items (500x500 baskets) PNC 867016
- Basket for 16 vertical glasses (h 70 mm - diam 100 mm) - blue PNC 867023

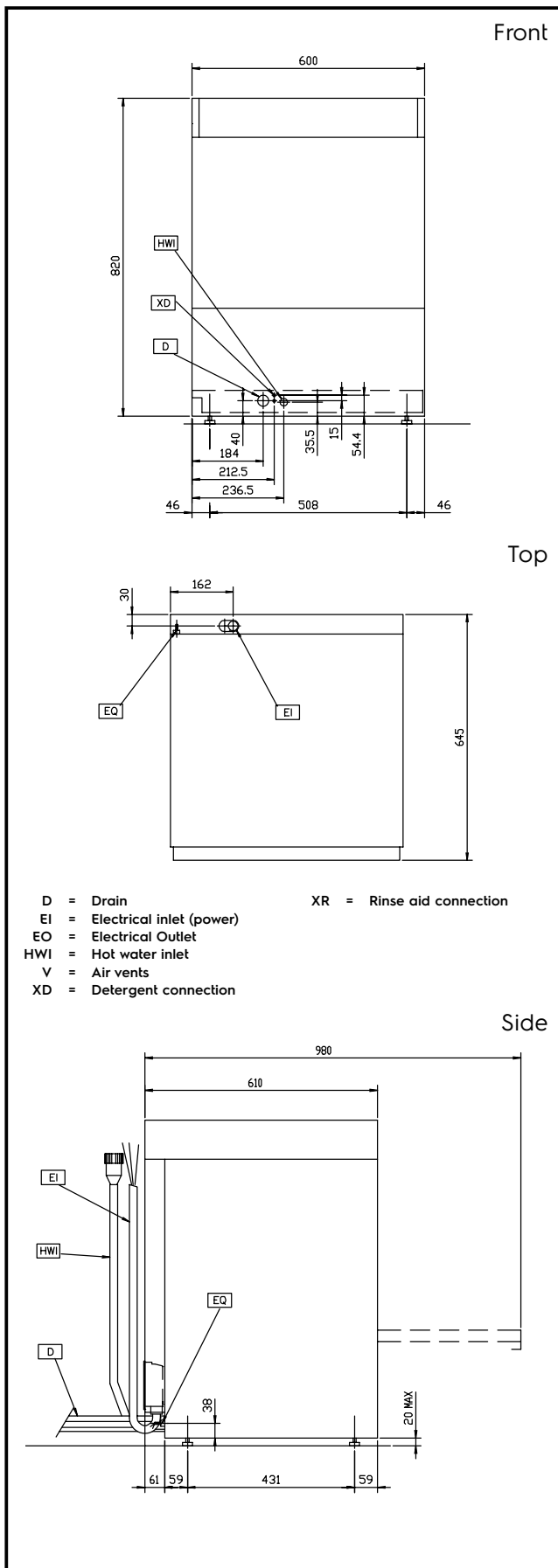

Electric

Supply voltage:	
400074 (EUCA1DDG)	230 V/1N ph/50 Hz
Convertible to:	230V 3~; 400V 3N~
Total Watts:	5.35 kW
Boiler heating elements:	4.5 kW
Tank heating elements:	2 kW
Wash pump size:	0.736 kW

Water:

Inlet water line size:	G 3/4"
Water supply temperature**:	50 °C
Drain line size:	20.5 mm
Inlet Water supply pressure:	7 - 102 psi (0.5 - 7 bar)
Water consumption per cycle (lt):	3
Working cycles time (sec.):	90/180
Boiler Capacity (lt):	5.8
Tank Capacity (lt):	33
Washing cycle temperature:	55-65 °C
Washing tank capacity (lt):	33
Washing cycle pump power:	0.736 kW
Washing cycle electrical elements:	2 kW
Hot rinse cycle duration (sec.):	12
Hot rinse cycle temperature:	84 °C
Hot rinse cycle water consumption (lt):	3

Key Information:

Baskets per hour:	40
Dishes per hour:	720
Wash temperature:	55-65°C
Rinse temperature:	84 °C
External dimensions, Height:	820 mm
External dimensions, Width:	600 mm
External dimensions, Depth:	610 mm
Noise level:	<70 dBA

Electrical supply cable included. Open air gap valve. Stainless steel tank filters included

Information:	
N° of working cycles - sec.:	2 (90/180)
Boiler type:	Atmospheric
Dishes capacity:	720/hr
Basket capacity:	40/h
Cell dimensions - width:	500 mm
Cell dimensions - depth:	500 mm
Cell dimensions - height:	330 mm